



## ATG (KSB, KSE) Planetary Reducers

### ATG (KSB, KSE) Planetary Reducers

ATG Series의 고정밀 유성치차 감속기는 Helical gear를 사용하고 있습니다. 모든 기어는 고정밀CNC 기어 가공기에서 제작되어 기어 맞물림이 정확하며 가동은 부드럽고 소음은 최소화입니다.

일체형 기어박스 본체는 타사동급 제품에 비해 더 작은 구조(부피와 무게의 1/4이상 감소)이며 보다 큰 회전력과 효율을 자랑합니다.

ATG series high precision planetary gear reducer employs helical gears. All gears are high precision machined by CNC gear hobbing machine, providing high accuracy gear engagement, smooth running and minimum noise.

One-piece fabricated gear box body. When comparing with the competitive gear reducer, ATG gear reducer features smaller construction (Saves over 1/4 of volume and weight), higher torque output and higher transmission efficiency.

## Features of KSB, KSE Series

### Low Noise

65dB 이하

### Low Backlash

1 Stage는 1 Arc-min~5 Arc-min,  
2 Stage는 3 Arc-min~7 Arc-min으로 선택 설계 가능.

### High Efficiency

1 stage 모델 효율성 97% 이내,  
2 stage 모델은 94% 이내.

### High Input Speed

입력 속도 5000 RPM 이상 허용.

### High Torque

기존 Planetary 변속기어보다  
보다 높은 Torque.

### High Stability

높은 장력의 합금 사용.  
기어 표면 경화는 표면만 경화가 아닌  
기어 전체 경화로 만들어 짐.  
이는 기어의 수명 연장과 오랜 기간의 운전 후에도  
새 것 같은 정확성을 유지시켜 줌.

### High Speed Reduction Ratio

모듈 디자인 기어감속기  
유성기어 박스 연결가능  
감속비율 1/1000 이상

### Low Noise

Under 65dB

### Low Backlash

Backlash is under 5 Arc-min Available to select specification with 1 Arc-min of backlash. Backlash for two-stage speed reduction is within 7 Arc-min.

### High Efficiency

Efficiency for single stage model exceeds 97%.  
For two-stage model exceeds 94%.

### High Input Speed

Input speed allows for up to 5000 RPM.

### High Torque

Higher torque output than that of conventional planetary gear reducers.

### High Stability

Employs high tensile strength alloy steel. Gear hardening is made for the entire gear instead of only surface hardening, which extends gear service life and maintain high accuracy as new after a long period of operation.

### High Speed Reduction Ratio

The gear reducer is a modular design. The planetary gear box can be connected. Speed reduction ratio is 1/1000.

Quality First & Customer's Satisfaction

## Indication Of Model Numbers

KSB	90	10	P0	MOTOR
TYPE	MODEL	RATIO	BACKLASH CLASS	MOTOR TYPE
KSB	44	1-STAGE	1-STAGE	MOTOR BRAND & MODEL NO.
KSE	62	3~10	Ps ≤ 1 Arc-min	
KSB-A	90	2-STAGE	PO ≤ 3 Arc-min	
KSE-A	120	15~100	P1 ≤ 5 Arc-min	
	142	3-STAGE	2-STAGE	
	180	125~1000	Ps ≤ 3 Arc-min	
	220		PO ≤ 5 Arc-min	
	270		P1 ≤ 7 Arc-min	
	330			

KSBL	90	10	P0	MOTOR
TYPE	MODEL	RATIO	BACKLASH CLASS	MOTOR TYPE
KSBL	44	1-STAGE	1-STAGE	MOTOR BRAND & MODEL NO.
KSEL	62	3~20	Ps ≤ 2 Arc-min	
KSBL-A	90	2-STAGE	PO ≤ 4 Arc-min	
KSEL-A	120	15~200	P1 ≤ 6 Arc-min	
	142		P2 ≤ 8 Arc-min	
	180		2-STAGE	
	220		Ps ≤ 4 Arc-min	
			PO ≤ 7 Arc-min	
			P1 ≤ 9 Arc-min	
			P2 ≤ 12 Arc-min	

## A-TYPE의 정의

### 1. IN SHAFT SIZE

KSB-62-2 STAGE, KSB-142-2 STAGE, KSB-180-2 STAGE의 경우, 1/30 이하의 감속기에 MOTOR를 적용 시 감속기가 지원하는 IN SHAFT의 크기로 인해 조립할 수 없는 경우가 발생합니다. 이러한 경우 KSB-A TYPE의 감속기를 사용하셔야 합니다.

EX) KSB-62-15-P1 (IN SHAFT SIZE 8)+MITSUBISHI KFS43 (IN SHAFT SIZE 14) → 조립불가  
 KSB-62A-15-P1 (IN SHAFT SIZE 14)+MITSUBISHI KFS43 (IN SHAFT SIZE 14) → 조립가능

MODEL	1 STAGE-IN SHAFT SIZE	2 STAGE-IN SHAFT SIZE	A-TYPE
44	8	8	8
62	14	8	14
90	19	14	19
120	24	19	24
142	35	24	35
180	55	35	55
220	55	55	55

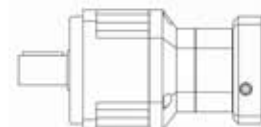

Standard

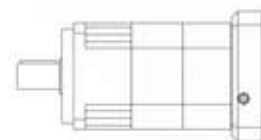

A-TYPE

일반적으로 감속비가 1/15~1/30일 경우 감속기의 정격 및 최대 토오크 값이 모터의 정격 및 최대 토오크 범주 안에 속하기 때문에 안정성 있는 사용 환경을 보장합니다.

### 2. 외관형태

KSB 감속기는 2-STAGE 부분이 더 작아지는 외관을 가지고 있습니다.

1-STAGE와 2-STAGE 부분의 SIZE가 동일한 제품을 사용하셔야 하실 경우, A-TYPE의 감속기를 선정하셔야 합니다.



KSEL

# ATG SERVOBOX Planetary Reducers

## MODEL : KSEL

Single Reduction

RATIO : 3.4.5.6.7.8.9.10.12.14.16.18.20

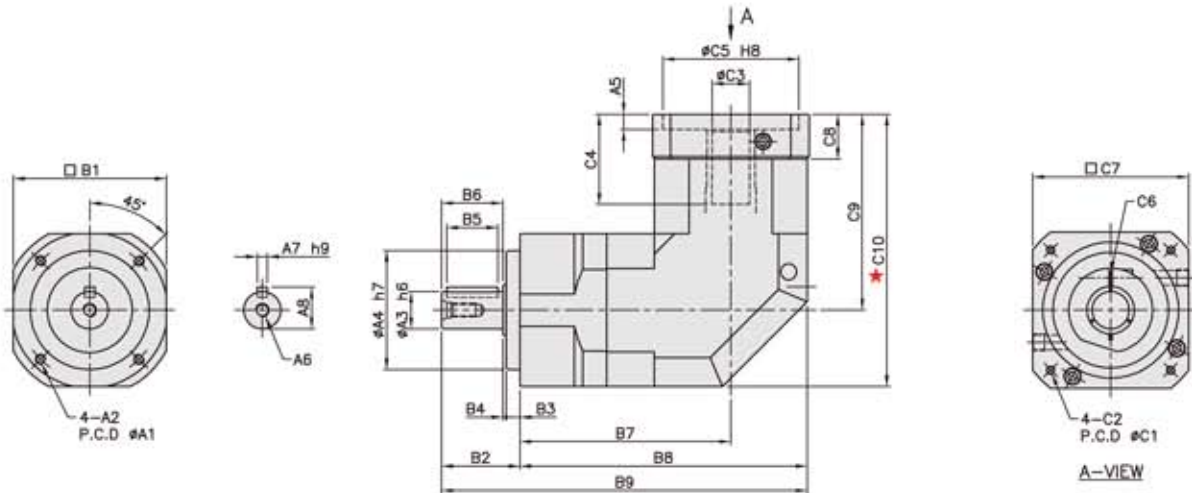

unit:mm

Model code	44	62	90	120	142	180	220
<b>A</b> A1	44	62	82	110	140	184	218
A2	M4×P0.7	M5×P0.8	M6×P1.0	M8×P1.25	M10×P1.5	M12×P1.75	M16×P2.0
A3	13	16	22	32	40	55	75
A4	35	50	70	90	120	160	180
A5	6	6	9, 23.5	10, 20	10	12.5	12.5
A6	M4×P0.7	M5×P0.8	M8×P1.25	M10×P1.5	M12×P1.75	M14×P2.0	M16×P2.0
A7	5	5	6	10	12	16	20
A8	15	18	24.5	35	43	59	79.5
<b>B</b> B1	44	62	90	120	142	180	220
B2	26	36	46	65	92	106	139
B3	5	7	8	12	15	20	30
B4	1	1	2	3	3	4	5
B5	15	20	30	40	65	70	90
B6	20	28	36	50	74	82	104
B7	76	84.5	124.1	148	165.3	223.6	231.6
B8	98	115.5	169.1	208	236.5	313.6	341.6
B9	124	151.5	215.1	273	328.5	419.6	480.6
<b>C</b> C1	46, 60, 63	70, 75, 90	90, 100, 115, 145	115, 145, 165	145, 165, 215	200, 215, 265	200, 265, 300
C2	M3, M4, M5	M4, M5, M6	M5, M6, M8	M6, M8, M10	M8, M10, M12	M10, M12	M12, M16
C3	8, (11)	14, (19)	19, (24)	24, (32)	35, (38)	38, 42, 48, 55	42, 48, 55
C4	27	33.5, 41.5	53, 67.5	67, 77	85	117	117
C5	30, 40, 50	50, 60, 70	70, 80, 95, 110	95, 110, 130	110, 130, 180	114.3, 180, 230	114.3, 230, 250
C6	M3×P0.5	M5×P0.8	M6×P1.0	M8×P1.25	M10×P1.5	M10×P1.5	M10×P1.5
C7	46, 55	64, 70, 80	92, 110, 130	122, 130, 150	146, 180, 190	182, 200, 250	222, 250, 265
C8	16	21.5	26.5, 41	35.5, 45.5	35.5	45.5	45.5
C9	61	77, 85	115.3, 129.8	141, 151	174	235	235
C10	83	108, 116	160.3, 174.8	201, 211	245	325	345



High Precision Planetary Reducer

■ Mass Moments of Inertia (kg · cm<sup>2</sup>)

Ratio	44	62	90	120	142	180	220
3	0.09	0.36	2.28	6.85	23.5	68.2	135.0
4	0.09	0.36	2.28	6.85	23.5	68.2	135.0
5	0.09	0.36	2.28	6.85	23.5	68.2	135.0
6	0.09	0.36	2.28	6.85	23.5	68.2	135.0
7	0.09	0.36	2.28	6.85	23.5	68.2	135.0
8	0.09	0.36	2.28	6.85	23.5	68.2	135.0
9	0.09	0.36	2.28	6.85	23.5	68.2	135.0
10	0.09	0.36	2.28	6.85	23.5	68.2	135.0
12	0.03	0.08	1.88	6.20	21.8	65.5	119.2
14	0.03	0.08	1.88	6.20	21.8	65.5	119.2
16	0.03	0.08	1.88	6.20	21.8	65.5	119.2
18	0.03	0.08	1.88	6.20	21.8	65.5	119.2
20	0.03	0.08	1.88	6.20	21.8	65.5	119.2

KSB

KSBL

KSE

KSEL

KSD

KSDL

KST

KGJ

KSF

KSFL

Model No		Unit	Ratio	44	62	90	120	142	180	220
Rated Output Torque (Nominal Output Torque)	$T_{2N}$	Nm	3	19	59	165	335	625	1,206	2,030
			4	16	51	146	300	555	1,069	1,804
			5	16	48	160	333	618	1,189	2,010
			6	15	45	151	311	583	1,118	1,911
			7	15	45	149	309	573	1,108	1,870
			8	14	43	143	298	553	1,070	1,824
			9	13	44	145	278	516	993	1,694
			10	14	43	141	294	549	1,059	1,779
			12	15	45	151	311	583	1,118	1,911
			14	15	45	149	309	573	1,108	1,870
			16	14	43	143	298	553	1,070	1,824
18	13	44	145	278	516	993	1,694			
20	14	43	141	294	549	1,059	1,779			
Max. Acceleration Torque	$T_{2B}$	Nm	3~20	1.8 Times of Rated Output Torque						
Max. Output Torque Emergency Stop Torque	$T_{2NOT}$	Nm	3~20	3 Times of Rated Output Torque						
Rated Input Speed	$n_{IN}$	rpm	3~20	4,000	4,000	4,000	3,000	3,000	3,000	2,000
Max. Input Speed	$n_{IB}$	rpm	3~20	8,000	8,000	6,000	5,000	4,000	4,000	3,000
Backlash P <sub>s</sub>		arcmin	3~20	-	≤2	≤2	≤2	≤2	≤2	≤2
Backlash P <sub>0</sub>		arcmin	3~20	≤4	≤4	≤4	≤4	≤4	≤4	≤4
Backlash P <sub>1</sub>		arcmin	3~20	≤6	≤6	≤6	≤6	≤6	≤6	≤6
Backlash P <sub>2</sub>		arcmin	3~20	≤8	≤8	≤8	≤8	≤8	≤8	≤8
Torsional Rigidity		Nm/arcmin	3~20	3	6	14	27	60	140	240
Max. Radial Force	$F_{2RB}$	N	3~20	760	1,180	3,200	6,800	9,300	15,600	51,000
Max. Axial Force	$F_{2AB}$	N	3~20	380	590	1,600	3,400	4,650	7,800	25,500
Service Life	$L_{H1}$	hr	3~20	20,000(Continuous Operation 10,000hrs)						
Efficiency	$\eta$	%	3~20	≥95						
Operating Temperature		°C	3~20	-25°C ~ +90°C						
Lubrication			3~20	VIGO GREASE RE #0						
Protection Class			3~20	IP65						
Mounting Position			3~20	ANY						
Noise Level		dB	3~20	≤65	≤68	≤70	≤72	≤74	≤76	≤78
Weight ±3%		Kg	3~20	0.88	2	6.58	13	22	41.7	63.2

\* 연속운전 사용시 본사와 상담후 선정바랍니다.



KSEL

# ATG SERVOBOX Planetary Reducers

## MODEL : KSEL

Double Reduction

RATIO : 15. 20. 25. 30. 35. 40. 50. 60. 70. 80.  
90. 100. 120. 140. 160. 180. 200

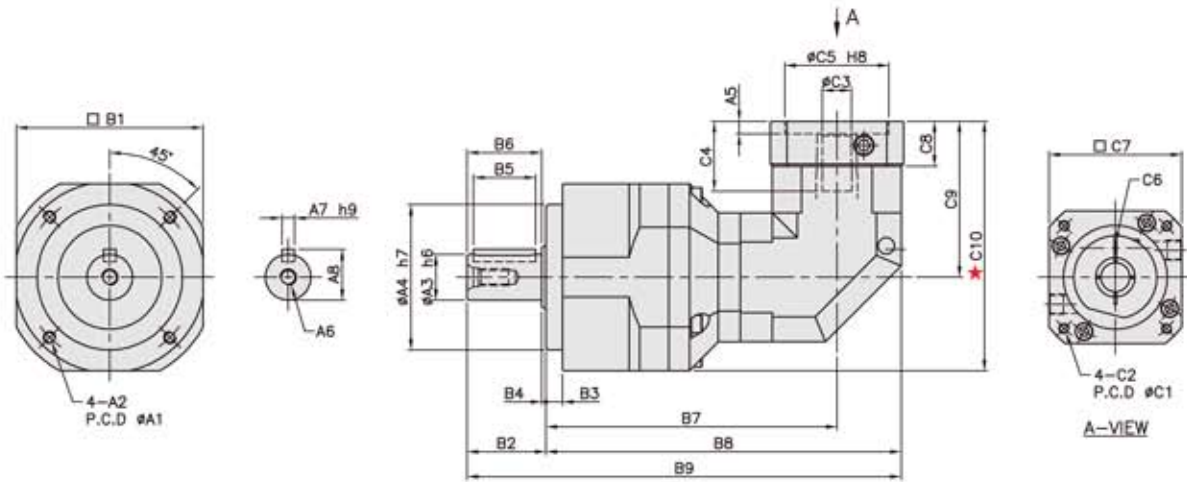

unit:mm

Model code	62	90	120	142	180	220
<b>A</b> A1	62	82	110	140	184	218
A2	M5×P0.8	M6×P1.0	M8×P1.25	M10×P1.5	M12×P1.75	M16×P2.0
A3	16	22	32	40	55	75
A4	50	70	90	120	160	180
A5	6	6	9, 23.5	10, 20	10	12.5
A6	M5×P0.8	M8×P1.25	M10×P1.5	M12×P1.75	M14×P2.0	M16×P2.0
A7	5	6	10	12	16	20
A8	18	24.5	35	43	59	79.5
<b>B</b> B1	62	90	120	142	180	220
B2	36	46	65	92	106	139
B3	7	8	12	15	20	30
B4	1	2	3	3	4	5
B5	20	30	40	65	70	90
B6	28	36	50	74	82	104
B7	110.5	132	181.6	214.5	249.5	313.6
B8	132.5	163	226.6	274.5	320.5	403.6
B9	168.5	209	291.6	366.5	426.5	542.6
<b>C</b> C1	46, 60, 63	70, 75, 90	90, 100, 115, 145	115, 145, 165	145, 165, 215	200, 215, 265
C2	M3, M4, M5	M4, M5, M6	M5, M6, M8	M6, M8, M10	M8, M10, M12	M10, M12
C3	8, (11)	14, (19)	19, (24)	24, (32)	35, (38)	38, 42, 48, 55
C4	27	33.5, 41.5	53, 67.5	67, 77	85	117
C5	30, 40, 50	50, 60, 70	70, 80, 95, 110	95, 110, 130	110, 130, 180	114.3, 180, 230
C6	M3×P0.5	M5×P0.8	M6×P1.0	M8×P1.25	M10×P1.5	M10×P1.5
C7	46, 55	64, 70, 80	92, 110, 130	122, 130, 150	146, 180, 190	182, 200, 250
C8	16	21.5	26.5, 41	35.5, 45.5	35.5	45.5
C9	61	77, 85	115.3, 129.8	141, 151	174	235
C10	92	122, 130	175.3, 189.8	212, 222	264	345



High Precision Planetary Reducer

■ Mass Moments of Inertia (kg · cm<sup>2</sup>)

Ratio	62	90	120	142	180	220
15	0.09	0.36	2.28	6.85	26.2	70.1
20	0.09	0.36	2.28	6.85	26.2	70.1
25	0.09	0.36	2.28	6.85	23.1	68.2
30	0.09	0.36	2.28	6.85	23.1	68.2
35	0.09	0.36	2.28	6.85	23.1	68.2
40	0.09	0.36	2.28	6.85	23.1	68.2
50	0.09	0.36	2.28	6.85	23.1	68.2
60	0.09	0.36	2.28	6.85	23.1	68.2
70	0.09	0.36	2.28	6.85	23.1	68.2
80	0.09	0.36	2.28	6.85	23.1	68.2
90	0.09	0.36	2.28	6.85	23.1	68.2
100	0.09	0.36	2.28	6.85	23.1	68.2
120	0.03	0.10	1.88	6.20	21.2	65.1
140	0.03	0.10	1.88	6.20	21.2	65.1
160	0.03	0.10	1.88	6.20	21.2	65.1
180	0.03	0.10	1.88	6.20	21.2	65.1
200	0.03	0.10	1.88	6.20	21.2	65.1

Model No		Unit	Ratio	62	90	120	142	180	220
Rated Output Torque (Nominal Output Torque)	$T_{2N}$	Nm	15	59	165	335	625	1,206	2,030
			20	51	146	300	555	1,069	1,804
			25	48	160	333	618	1,189	2,010
			30	45	151	311	583	1,118	1,911
			35	45	149	309	573	1,108	1,870
			40	43	143	298	553	1,070	1,824
			50	48	160	333	618	1,189	2,010
			60	45	151	311	583	1,118	1,911
			70	45	149	309	573	1,108	1,870
			80	43	143	298	553	1,070	1,824
			90	44	145	278	516	993	1,694
			100	43	141	294	549	1,059	1,779
			120	45	151	311	583	1,118	1,911
			140	45	149	309	573	1,108	1,870
160	43	143	298	553	1,070	1,824			
180	44	145	278	516	993	1,694			
200	43	141	294	549	1,059	1,779			
Max. Acceleration Torque	$T_{2B}$	Nm	15~200	1.8 Times of Rated Output Torque					
Max. Output Torque Emergency Stop Torque	$T_{2NOT}$	Nm	15~200	3 Times of Rated Output Torque					
Rated Input Speed	$n_{IN}$	rpm	15~200	4,000	4,000	3,000	3,000	3,000	2,000
Max. Input Speed	$n_{in}$	rpm	15~200	8,000	6,000	5,000	4,000	4,000	3,000
Backlash P <sub>s</sub>		arcmin	15~200	-	≤4	≤4	≤4	≤4	≤4
Backlash P <sub>0</sub>		arcmin	15~200	≤7	≤7	≤7	≤7	≤7	≤7
Backlash P <sub>1</sub>		arcmin	15~200	≤9	≤9	≤9	≤9	≤9	≤9
Backlash P <sub>2</sub>		arcmin	15~200	≤12	≤12	≤12	≤12	≤12	≤12
Torsional Rigidity		Nm/arcmin	15~200	6	14	27	60	140	240
Max. Radial Force	$F_{2B}$	N	15~200	1,180	3,200	6,800	9,300	15,600	51,000
Max. Axial Force	$F_{2aB}$	N	15~200	590	1,600	3,400	4,650	7,800	25,500
Service Life	$L_{H1}$	hr	15~200	20,000(Continuous Operation 10,000hrs)					
Efficiency	$\eta$	%	15~200	≥92					
Operating Temperature		°C	15~200	-25°C~ +90°C					
Lubrication			15~200	VIGO GREASE RE #0					
Protection Class			15~200	IP65					
Mounting Position			15~200	ANY					
Noise Level		dB	15~200	≤68	≤70	≤72	≤74	≤76	≤78
Weight ±3%		Kg	15~200	2.4	7.98	12.6	26.8	50.9	72

\* 연속운전 사용시 본사와 상담후 선정바랍니다.



KSEL

# ATG SERVOBOX Planetary Reducers

## MODEL : KSEL-A

Double Reduction

RATIO : 15. 20. 25. 30. 35. 40. 50. 60. 70. 80.

90. 100. 120. 140. 160. 180. 200

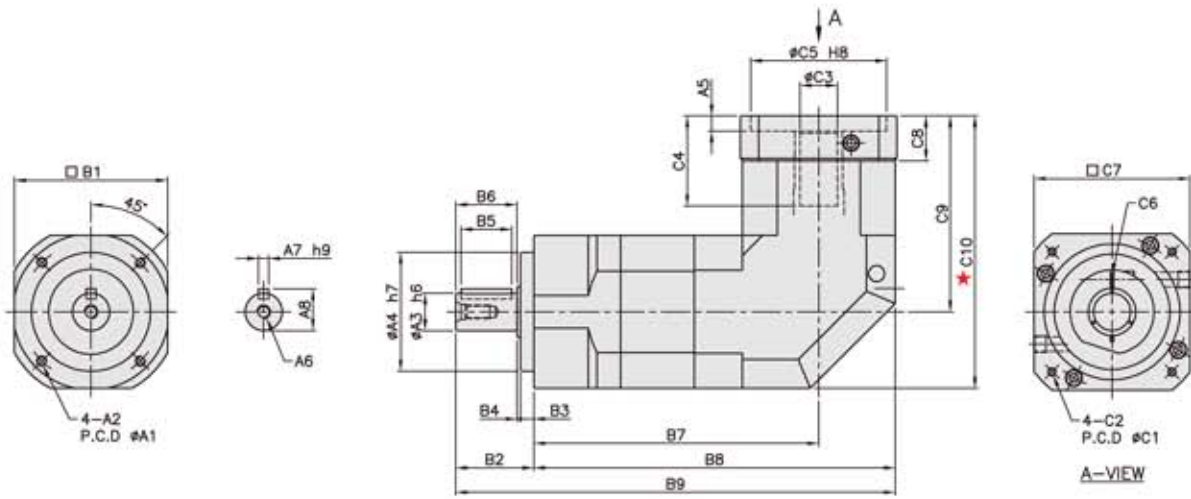

unit:mm

Model code	44A	62A	90A	120A	142A	180A	220A
<b>A</b>							
A1	44	62	82	110	140	184	218
A2	M4×P0.7	M5×P0.8	M6×P1.0	M8×P1.25	M10×P1.5	M12×P1.75	M16×P2.0
A3	13	16	22	32	40	55	75
A4	35	50	70	90	120	160	180
A5	6	6	9, 23.5	10, 20	10	12.5	12.5
A6	M4×P0.7	M5×P0.8	M8×P1.25	M10×P1.5	M12×P1.75	M14×P2.0	M16×P2.0
A7	5	5	6	10	12	16	20
A8	15	18	24.5	35	43	59	79.5
<b>B</b>							
B1	44	62	90	120	142	180	220
B2	26	36	46	65	92	106	139
B3	5	7	8	12	15	20	30
B4	1	1	2	3	3	4	5
B5	15	20	30	40	65	70	90
B6	20	28	36	50	74	82	104
B7	102	118.3	167.6	204	232	304.6	324.6
B8	124	149.3	212.6	264	303	394.6	434.6
B9	150	185.3	258.6	329	395	500.6	573.6
<b>C</b>							
C1	46, 60, 63	70, 75, 90	90, 100, 115, 145	115, 145, 165	145, 165, 215	200, 215, 265	200, 265, 300
C2	M3, M4, M5	M4, M5, M6	M5, M6, M8	M6, M8, M10	M8, M10, M12	M10, M12	M12, M16
C3	8, (11)	14, (19)	19, (24)	24, (32)	35, (38)	38, 42, 48, 55	42, 48, 55
C4	27	33.5, 41.5	53, 67.5	67, 77	85	117	117
C5	30, 40, 50	50, 60, 70	70, 80, 95, 110	95, 110, 130	110, 130, 180	114.3, 180, 230	114.3, 230, 250
C6	M3×P0.5	M5×P0.8	M6×P1.0	M8×P1.25	M10×P1.5	M10×P1.5	M10×P1.5
C7	46, 55	64, 70, 80	92, 110, 130	122, 130, 150	146, 150, 190	182, 200, 250	222, 250, 265
C8	16	21.5	26.5, 41	35.5, 45.5	35.5	45.5	45.5
C9	61	77, 85	115.3, 129.8	141, 151	174	235	235
C10	83	108, 116	160.3, 174.8	201, 211	245	325	345



High Precision Planetary Reducer

■ Mass Moments of Inertia (kg · cm<sup>2</sup>)

Ratio	44A	62A	90A	120A	142A	180A	220
15	0.09	0.36	2.28	6.85	23.45	55.2	80.2
20	0.09	0.36	2.28	6.85	23.45	55.2	80.2
25	0.09	0.36	2.28	6.85	23.45	50.4	76.5
30	0.09	0.36	2.28	6.85	23.50	50.4	76.5
35	0.09	0.36	2.28	6.85	23.50	50.4	76.5
40	0.09	0.36	2.28	6.85	23.50	50.4	76.5
50	0.09	0.36	2.28	6.85	23.50	50.4	76.5
60	0.09	0.36	2.28	6.85	23.50	50.4	76.5
70	0.09	0.36	2.28	6.85	23.50	50.4	76.5
80	0.09	0.36	2.28	6.85	23.50	50.4	76.5
90	0.09	0.36	2.28	6.85	23.50	50.4	76.5
100	0.09	0.36	2.28	6.85	23.50	50.4	76.5
120	0.03	0.08	1.88	6.20	21.80	48.7	74.2
140	0.03	0.08	1.88	6.20	21.80	48.7	74.2
160	0.03	0.08	1.88	6.20	21.80	48.7	74.2
180	0.03	0.08	1.88	6.20	21.80	48.7	74.2
200	0.03	0.08	1.88	6.20	21.80	48.7	74.2

Model No		Unit	Ratio	44A	62A	90A	120A	142A	180A	220A
Rated Output Torque (Nominal Output Torque)	$T_{2N}$	Nm	15	19	59	165	335	625	1,206	2,030
			20	16	51	146	300	555	1,069	1,804
			25	16	48	160	333	618	1,189	2,010
			30	15	45	151	311	583	1,118	1,911
			35	15	45	149	309	573	1,108	1,870
			40	14	43	143	298	553	1,070	1,824
			50	16	48	160	333	618	1,189	2,010
			60	15	45	151	311	583	1,118	1,911
			70	15	45	149	309	573	1,108	1,870
			80	14	43	143	298	553	1,070	1,824
			90	13	44	145	278	516	993	1,694
			100	14	43	141	294	549	1,059	1,779
			120	15	45	151	311	583	1,118	1,911
			140	15	45	149	309	573	1,108	1,870
			160	14	43	143	298	553	1,070	1,824
			180	13	44	145	278	516	993	1,694
200	14	43	141	294	549	1,059	1,779			
Max. Acceleration Torque	$T_{2B}$	Nm	15~200	1.8 Times of Rated Output Torque						
Max. Output Torque Emergency Stop Torque	$T_{2NOT}$	Nm	15~200	3 Times of Rated Output Torque						
Rated Input Speed	$n_{IN}$	rpm	15~200	4,000	4,000	4,000	3,000	3,000	3,000	2,000
Max. Input Speed	$n_{IB}$	rpm	15~200	8,000	8,000	6,000	5,000	4,000	4,000	3,000
Backlash P5		arcmin	15~200	-	-	≤4	≤4	≤4	≤4	≤4
Backlash P0		arcmin	15~200	≤7	≤7	≤7	≤7	≤7	≤7	≤7
Backlash P1		arcmin	15~200	≤9	≤9	≤9	≤9	≤9	≤9	≤9
Backlash P2		arcmin	15~200	≤12	≤12	≤12	≤12	≤12	≤12	≤12
Torsional Rigidity		Nm/arcmin	15~200	3	6	14	27	60	140	240
Max. Radial Force	$F_{2RB}$	N	15~200	760	1,180	3,200	6,800	9,300	15,600	51,000
Max. Axial Force	$F_{2aB}$	N	15~200	380	590	1,600	3,400	4,650	7,800	25,500
Service Life	$L_{H1}$	hr	15~200	20,000(Continuous Operation 10,000hrs)						
Efficiency	$\eta$	%	15~200	≥92						
Operating Temperature		°C	15~200	-25°C~ +90°C						
Lubrication			15~200	VIGO GREASE RE #0						
Protection Class			15~200	IP65						
Mounting Position			15~200	ANY						
Noise Level		dB	15~200	≤65	≤68	≤70	≤72	≤74	≤76	≤78
Weight ±3%		Kg	15~200	1.1	3.3	9.98	16.5	31.5	65.5	91

\* 연속운전 사용시 본사와 상담후 선정바랍니다.



Foot

# ATG Planetary Reducers

## ACCESSORIES

### Foot Type Base Kits

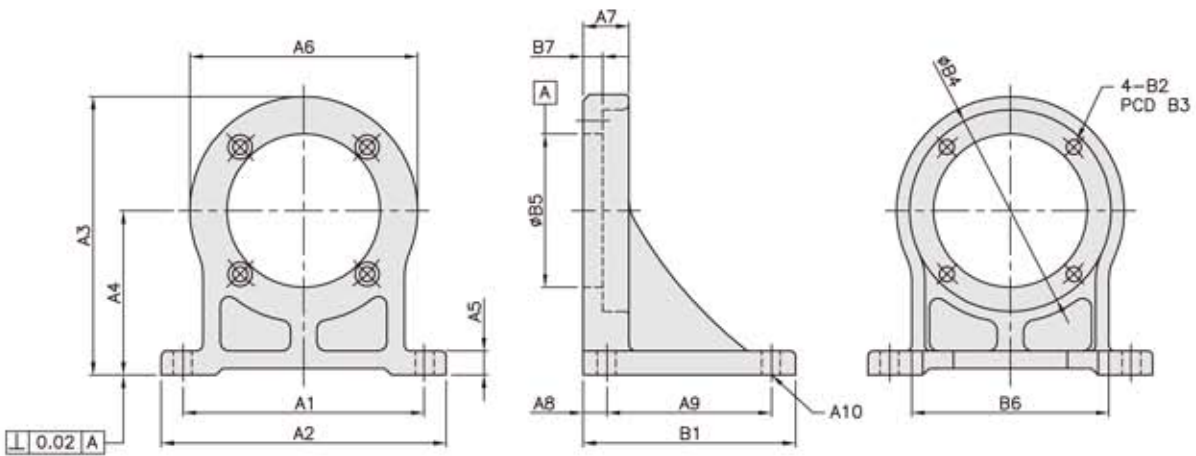

unit:mm

Model Code	44	62	90	120	142	180	220
<b>A</b> A1	70	90	110	150	190	240	280
A2	88	108	130	176	220	276	330
A3	75.5	95.5	127	170	207.5	274	334
A4	45	55	75	100	120	160	200
A5	8	9	11	16	19	24	30
A6	60	81	104	140	175	228	268
A7	13	16	21	28	35	45	60
A8	10	10	11	14	16	19	26
A9	40	50	75	100	120	160	200
A10	4-Ø7	4-Ø7	4-Ø9	4-Ø11	4-Ø13	4-Ø17	4-Ø21
<b>B</b> B1	60	70	97	128	152	198	252
B2	Ø4.5	Ø5.5	Ø6.8	Ø9	Ø11	Ø13	Ø17
B3	44	62	82	110	140	184	218
B4	50	70	92	124	155	205	242
B5	35	50	70	90	120	160	180
B6	50	70	90	125	156	200	230
B7	6	8	9	14	16	21	30
Weight Kg	0.55	0.71	1.57	3.86	6.41	13.44	27.73



# Connecting Plate

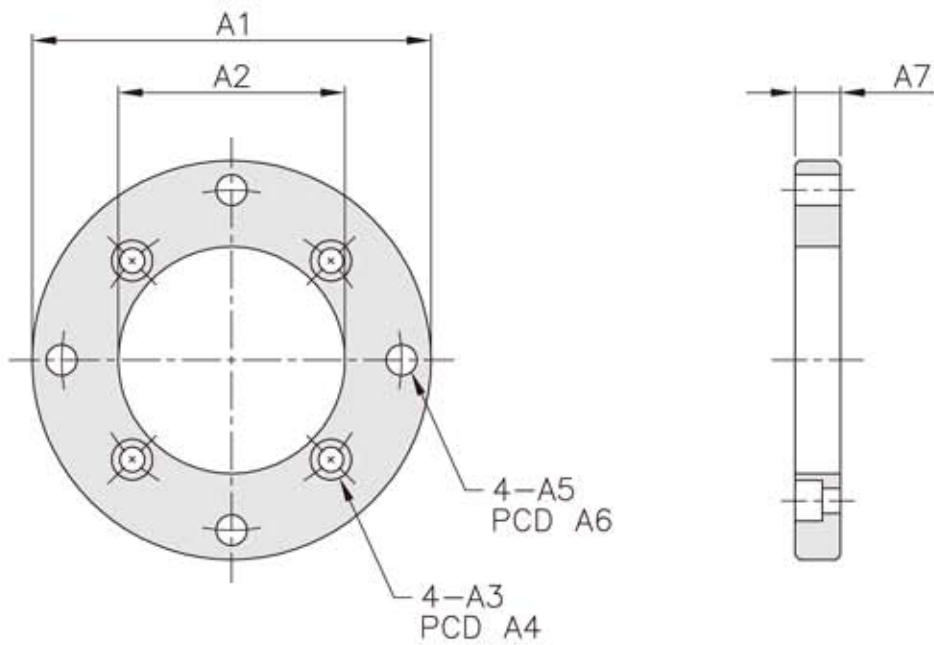

unit: mm

Model Code	44	62	90	120	142	180	220
	<b>A</b> A1	64	88	123	158	188	238
A2	35	50	70	90	120	160	180
A3	4.5	5.5	6.8	9	11	13	17
A4	44	62	82	110	140	184	218
A5	5.5	6.8	9	11	13	15	17
A6	54	75	106	140	165	210	260
A7	8	9	11	14	17	22	30