



ATG (KSB, KSE) Planetary Reducers

ATG (KSB, KSE) Planetary Reducers

ATG Series의 고정밀 유성치차 감속기는 Helical gear를 사용하고 있습니다. 모든 기어는 고정밀CNC 기어 가공기에서 제작되어 기어 맞물림이 정확하며 가동은 부드럽고 소음은 최소화입니다.

일체형 기어박스 본체는 타사동급 제품에 비해 더 작은 구조(부피와 무게의 1/4이상 감소)이며 보다 큰 회전력과 효율을 자랑합니다.

ATG series high precision planetary gear reducer employs helical gears. All gears are high precision machined by CNC gear hobbing machine, providing high accuracy gear engagement, smooth running and minimum noise.

One-piece fabricated gear box body. When comparing with the competitive gear reducer, ATG gear reducer features smaller construction (Saves over 1/4 of volume and weight), higher torque output and higher transmission efficiency.

Features of KSB, KSE Series

Low Noise

65dB 이하

Low Backlash

1 Stage는 1 Arc-min~5 Arc-min,
2 Stage는 3 Arc-min~7 Arc-min으로 선택 설계 가능.

High Efficiency

1 stage 모델 효율성 97% 이내,
2 stage 모델은 94% 이내.

High Input Speed

입력 속도 5000 RPM 이상 허용.

High Torque

기존 Planetary 변속기어보다
보다 높은 Torque.

High Stability

높은 장력의 합금 사용.
기어 표면 경화는 표면만 경화가 아닌
기어 전체 경화로 만들어 짐.
이는 기어의 수명 연장과 오랜 기간의 운전 후에도
새 것 같은 정확성을 유지시켜 줌.

High Speed Reduction Ratio

모듈 디자인 기어감속기
유성기어 박스 연결가능
감속비율 1/1000 이상

Low Noise

Under 65dB

Low Backlash

Backlash is under 5 Arc-min Available to select specification with 1 Arc-min of backlash. Backlash for two-stage speed reduction is within 7 Arc-min.

High Efficiency

Efficiency for single stage model exceeds 97%.
For two-stage model exceeds 94%.

High Input Speed

Input speed allows for up to 5000 RPM.

High Torque

Higher torque output than that of conventional planetary gear reducers.

High Stability

Employs high tensile strength alloy steel. Gear hardening is made for the entire gear instead of only surface hardening, which extends gear service life and maintain high accuracy as new after a long period of operation.

High Speed Reduction Ratio

The gear reducer is a modular design. The planetary gear box can be connected. Speed reduction ratio is 1/1000.

Quality First & Customer's Satisfaction

Indication Of Model Numbers

KSB	90	10	P0	MOTOR
TYPE	MODEL	RATIO	BACKLASH CLASS	MOTOR TYPE
KSB	44	1-STAGE	1-STAGE	MOTOR BRAND & MODEL NO.
KSE	62	3~10	Ps ≤ 1 Arc-min	
KSB-A	90	2-STAGE	PO ≤ 3 Arc-min	
KSE-A	120	15~100	P1 ≤ 5 Arc-min	
	142	3-STAGE	2-STAGE	
	180	125~1000	Ps ≤ 3 Arc-min	
	220		PO ≤ 5 Arc-min	
	270		P1 ≤ 7 Arc-min	
	330			

KSBL	90	10	P0	MOTOR
TYPE	MODEL	RATIO	BACKLASH CLASS	MOTOR TYPE
KSBL	44	1-STAGE	1-STAGE	MOTOR BRAND & MODEL NO.
KSEL	62	3~20	Ps ≤ 2 Arc-min	
KSBL-A	90	2-STAGE	PO ≤ 4 Arc-min	
KSEL-A	120	15~200	P1 ≤ 6 Arc-min	
	142		P2 ≤ 8 Arc-min	
	180		2-STAGE	
	220		Ps ≤ 4 Arc-min	
			PO ≤ 7 Arc-min	
			P1 ≤ 9 Arc-min	
			P2 ≤ 12 Arc-min	

A-TYPE의 정의

1. IN SHAFT SIZE

KSB-62-2 STAGE, KSB-142-2 STAGE, KSB-180-2 STAGE의 경우, 1/30 이하의 감속기에 MOTOR를 적용 시 감속기가 지원하는 IN SHAFT의 크기로 인해 조립할 수 없는 경우가 발생합니다. 이러한 경우 KSB-A TYPE의 감속기를 사용하셔야 합니다.

EX) KSB-62-15-P1 (IN SHAFT SIZE 8)+MITSUBISHI KFS43 (IN SHAFT SIZE 14) → 조립불가
 KSB-62A-15-P1 (IN SHAFT SIZE 14)+MITSUBISHI KFS43 (IN SHAFT SIZE 14) → 조립가능

MODEL	1 STAGE-IN SHAFT SIZE	2 STAGE-IN SHAFT SIZE	A-TYPE
44	8	8	8
62	14	8	14
90	19	14	19
120	24	19	24
142	35	24	35
180	55	35	55
220	55	55	55

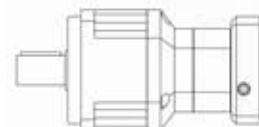

Standard

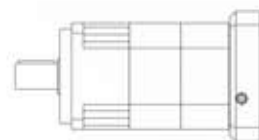

A-TYPE

일반적으로 감속비가 1/15~1/30일 경우 감속기의 정격 및 최대 토오크 값이 모터의 정격 및 최대 토오크 범주 안에 속하기 때문에 안정성 있는 사용 환경을 보장합니다.

2. 외관형태

KSB 감속기는 2-STAGE 부분이 더 작아지는 외관을 가지고 있습니다.

1-STAGE와 2-STAGE 부분의 SIZE가 동일한 제품을 사용하셔야 하실 경우, A-TYPE의 감속기를 선정하셔야 합니다.

KSE

ATG SERVOBOX Planetary Reducers



MODEL : KSE

Single Reduction

RATIO : 3.4.5.6.7.8.9.10

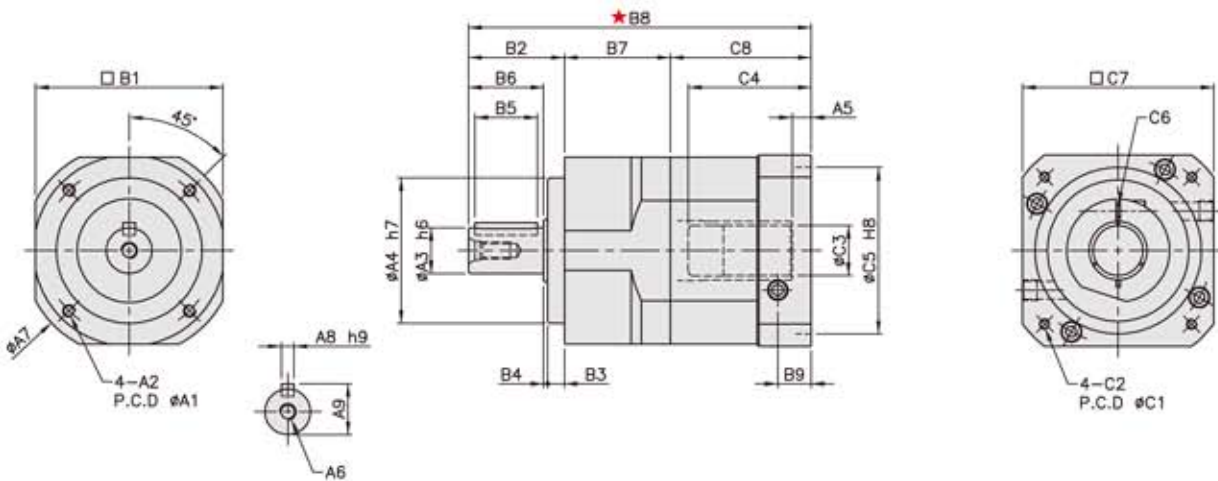

unit:mm

Model code	44	62	90	120	142	180	220	270	330
A	A1 44	A2 M4×P0.7	A3 13	A4 35	A5 5	A6 M4×P0.7	A7 50	A8 5	A9 15
B	B1 44	B2 26	B3 5	B4 1	B5 15	B6 20	B7 31.5	B8 95	B9 9
C	C1 46, 60, 63	C2 M3, M4, M5	C3 8, (11)	C4 26	C5 30, 40, 50	C6 M3×P0.5	C7 46, 55	C8 37.5	
	62	90	120	142	180	220	270	330	
	82	M5×P0.8	22	70	6	M5×P0.8	70	18	
	32	16	22	70	9	M6×P1.0	102	24.5	
	90	50	70	90	10	M8×P1.25	134	35	
	10	6	9	10	10	M10×P1.5	166	43	
	M10×P1.5	M5×P0.8	M8×P1.25	M10×P1.5	M12×P1.75	M14×P2.0	215	59	
	120	70	102	134	166	215	252	79.5	
	12	7	8	12	15	20	270	90	
	10	1	2	3	3	4	336	106	
	12	20	30	40	65	70	370	110	
	20	28	36	50	74	82	404	130	
	20	36	46	65	92	106	439	171	
	30	38	51	61	70	85	463	142	
	30	115, 123	151.5, 164.5	205	260.5	323.5	367.5	464.5, 474.5	493, 503
	19.5	11.5	16	19.5	20	23.5	23.5	26, 36	26, 36
	200, 215, 265	70, 75, 90	90, 100, 115, 145	115, 145, 165	145, 165, 215	200, 215, 265	200, 265, 300	300, 350	300, 350
	M10, M12	M4, M5, M6	M5, M6, M8	M6, M8, M10	M8, M10, M12	M10, M12	M12, M16	M16, M18	M16, M18
	38, 42, 48, 55	14, (19)	19, (24)	24, (32)	35, (38)	38, 42, 48, 55	42, 48, 55	48, 55, 60	55, 60, 75
	114.5	33.5, 41.5	46, 59	67	84.5	114.5	117.5	133, 143	133, 143
	114.3, 180, 230	50, 60, 70	70, 80, 95, 110	95, 110, 130	110, 130, 180	114.3, 180, 230	114.3, 230, 250	250, 300	250, 300
	M10×P1.5	M5×P0.8	M6×P1.0	M8×P1.25	M10×P1.5	M10×P1.5	M10×P1.5	M12×P1.75	M12×P1.75
	182, 200, 250	64, 70, 80	92, 110, 130	122, 130, 150	146, 150, 190	182, 200, 250	222, 250, 265	300, 330	300, 330
	132.5	41, 49	54.5, 67.5	79	98.5	132.5	135.5	151.5, 161.5	146, 156



High Precision Planetary Reducer

KSB
KSBF
KSE
KSEL
KSD
KSDL
KST
KGT
KSF
KSFL

■ Mass Moments of Inertia (kg · cm²)

Ratio	44	62	90	120	142	180	220	270	330
3	0.03	0.16	0.61	3.25	9.21	28.98	69.61	122.20	252.96
4	0.03	0.14	0.48	2.74	7.54	23.67	54.37	111.46	230.72
5	0.03	0.13	0.47	2.71	7.42	23.29	53.27	109.20	226.05
6	0.03	0.13	0.45	2.65	7.25	22.75	51.72	106.03	219.47
7	0.03	0.13	0.45	2.62	7.14	22.48	50.97	104.49	216.29
8	0.03	0.13	0.44	2.58	7.07	22.59	50.84	104.22	215.74
9	0.03	0.13	0.44	2.57	7.04	22.53	50.63	103.79	214.85
10	0.03	0.13	0.44	2.57	7.03	22.51	50.56	103.65	214.55

Model No.	Unit	Ratio	44	62	90	120	142	180	220	270	330	
Rated Output Torque (Nominal Output Torque)	Nm	3	19	59	165	335	625	1,206	2,030	4,770	8,790	
		4	16	51	146	300	555	1,069	1,804	4,730	8,730	
		5	16	48	160	333	618	1,189	2,010	4,680	8,660	
		6	15	45	151	311	583	1,118	1,911	4,620	8,610	
		7	15	45	149	309	573	1,108	1,870	4,570	8,520	
		8	14	43	143	298	553	1,070	1,824	4,520	8,440	
		9	13	44	145	278	516	993	1,694	4,450	8,370	
		10	14	43	141	294	549	1,059	1,779	4,420	8,310	
Max. Acceleration Torque	T_{2B}	Nm	3-10	1.8 Times of Rated Output Torque								
Max. Output Torque Emergency Stop Torque	T_{2NOT}	Nm	3-10	3 Times of Rated Output Torque								
Rated Input Speed	n_{IN}	rpm	3-10	5,000	5,000	4,000	4,000	3,000	3,000	2,000	2,000	
Max. Input Speed	n_{IB}	rpm	3-10	10,000	10,000	8,000	8,000	6,000	6,000	4,000	3,000	
Backlash P _s		arcmin	3-10	—	≤1	≤1	≤1	≤1	≤1	≤1	≤1	
Backlash P ₀		arcmin	3-10	≤3	≤3	≤3	≤3	≤3	≤3	≤3	≤3	
Backlash P ₁		arcmin	3-10	≤5	≤5	≤5	≤5	≤5	≤5	≤5	≤5	
Torsional Rigidity		Nm/arcmin	3-10	3	6	14	27	60	140	240	980	
Max. Radial Force	F_{2rB}	N	3-10	760	1,180	3,200	6,800	9,300	15,600	51,000	107,100	
Max. Axial Force	F_{2aB}	N	3-10	380	590	1,600	3,400	4,650	7,800	25,500	53,550	
Service Life	L_{H1}	hr	3-10	20,000(Continuous Operation 10,000hrs)								
Efficiency	η	%	3-10	≥97								
Operating Temperature		°C	3-10	-25°C- +90°C								
Lubrication			3-10	VIGO GREASE RE #0								
Protection Class			3-10	IP65								
Mounting Position			3-10	ANY								
Noise Level		dB	3-10	≤56	≤58	≤60	≤63	≤65	≤67	≤70	≤72	
Weight ±3%		Kg	3-10	0.58	1.32	3.4	7.88	14	29.16	39	104	

* 연속운전 사용시 본사와 상담후 선정바랍니다.

KSE

ATG SERVOBOX Planetary Reducers



MODEL : KSE

Double Reduction

RATIO : 15. 20. 25. 30. 35. 40. 50. 60. 70. 80. 90. 100

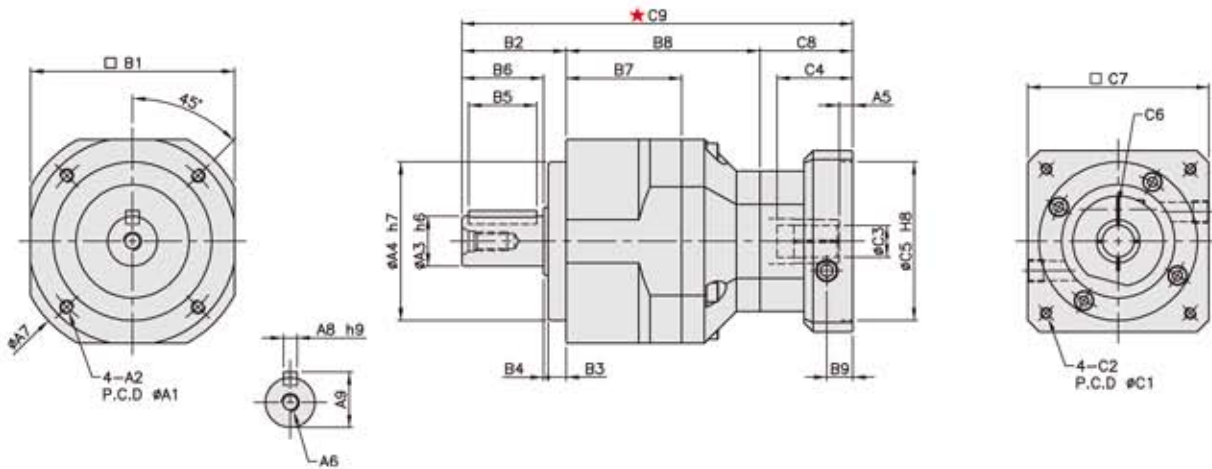

unit:mm

Model code	62	90	120	142	180	220	270	330
A								
A1	62	82	110	140	184	218	240	300
A2	M5×P0.8	M6×P1.0	M8×P12.5	M10×P1.5	M12×P1.75	M16×P2.0	8-M12	8-M16
A3	16	22	32	40	55	75	85	100
A4	50	70	90	120	160	180	200	250
A5	5	6	9	10	10	11.5	12.5	13, 23
A6	M5×P0.8	M8×P1.25	M10×P1.5	M12×P1.75	M14×P2.0	M16×P2.0	M20×P2.5	M24×P3.0
A7	70	102	134	166	215	252	270	336
A8	5	6	10	12	16	20	22	28
A9	18	24.5	35	43	59	79.5	90	106
B								
B1	62	90	120	142	180	220	-	-
B2	36	46	65	92	106	139	171	188
B3	7	8	12	15	20	30	36	42
B4	1	2	3	3	4	5	5	6
B5	20	30	40	65	70	90	110	120
B6	28	36	50	74	82	104	130	140
B7	38	51	61	70	85	93	142	159
B8	66	85.5	108.5	127.5	154	175	237.5	274.5
B9	9	11.5	16	19.5	20	23.5	23.5	26, 36
C								
C1	46, 60, 63	70, 75, 90	90, 100, 115, 145	115, 145, 165	145, 165, 215	200, 215, 265	200, 265, 300	300, 350
C2	M3, M4, M5	M4, M5, M6	M5, M6, M8	M6, M8, M10	M8, M10, M12	M10, M12	M12, M16	M16, M18
C3	8, (11)	14, (19)	19, (24)	24, (32)	35, (38)	38, 42, 48, 55	42, 48, 55	48, 55, 60
C4	26	33.5, 41.5	46, 59	67	84.5	114.5	117.5	133, 143
C5	30, 40, 50	50, 60, 70	70, 80, 95, 110	95, 110, 130	110, 130, 180	114.3, 180, 230	114.3, 230, 250	250, 300
C6	M3×P0.5	M5×P0.8	M6×P1.0	M8×P1.25	M10×P1.5	M10×P1.5	M10×P1.5	M12×P1.75
C7	46, 55	64, 70, 80	92, 110, 130	122, 130, 150	146, 150, 190	182, 200, 250	222, 250, 265	300, 330
C8	37.5	41, 49	54.5, 67.5	79	98.5	132.5	135.5	151.5, 161.5
C9	139.5	172.5, 180.5	228, 241	298.5	358.5	446.5	544	614, 624



High Precision Planetary Reducer

■ Mass Moments of Inertia (kg · cm²)

Ratio	62	90	120	142	180	220	270	330
15	0.03	0.14	0.46	2.63	7.30	22.79	63.81	185.05
20	0.03	0.14	0.46	2.63	7.30	22.79	63.81	185.05
25	0.03	0.14	0.46	2.63	7.10	22.79	63.81	185.05
30	0.03	0.14	0.46	2.43	7.10	22.59	63.25	183.43
35	0.03	0.14	0.44	2.43	7.10	22.59	63.25	183.43
40	0.03	0.14	0.44	2.43	6.92	22.59	63.25	183.43
50	0.03	0.14	0.44	2.43	6.92	22.59	63.25	183.43
60	0.03	0.14	0.43	2.39	6.72	21.83	61.12	177.26
70	0.03	0.14	0.43	2.39	6.72	21.83	61.12	177.26
80	0.03	0.14	0.43	2.39	6.72	21.83	61.12	177.26
90	0.03	0.14	0.40	2.39	6.72	21.60	60.48	175.39
100	0.03	0.14	0.40	2.39	6.72	21.60	60.48	175.39

Model No.	Unit	Ratio	62	90	120	142	180	220	270	330	
Rated Output Torque (Nominal Output Torque)	T_{2N}	Nm	15	59	165	335	625	1,206	2,030	4,770	8,790
			20	51	146	300	555	1,069	1,804	4,730	8,730
			25	48	160	333	618	1,189	2,010	4,680	8,660
			30	45	151	311	583	1,118	1,911	4,620	8,610
			35	45	149	309	573	1,108	1,870	4,570	8,520
			40	43	143	298	553	1,070	1,824	4,520	8,440
			50	48	160	333	618	1,189	2,010	4,680	8,660
			60	45	151	311	583	1,118	1,911	4,620	8,610
			70	45	149	309	573	1,108	1,870	4,570	8,520
			80	43	143	298	553	1,070	1,824	4,520	8,440
90	44	145	278	516	993	1,694	4,450	8,370			
100	43	141	294	549	1,059	1,779	4,420	8,310			
Max. Acceleration Torque	T_{2H}	Nm	15~100	1.8 Times of Rated Output Torque							
Max. Output Torque Emergency Stop Torque	T_{2NOT}	Nm	15~100	3 Times of Rated Output Torque							
Rated Input Speed	n_{IN}	rpm	15~100	5,000	4,000	4,000	3,000	3,000	2,000	2,000	2,000
Max. Input Speed	n_{IB}	rpm	15~100	10,000	8,000	8,000	6,000	6,000	4,000	3,000	3,000
Backlash Ps		arcmin	15~100	-	≤3	≤3	≤3	≤3	≤3	≤3	≤3
Backlash P0		arcmin	15~100	≤5	≤5	≤5	≤5	≤5	≤5	≤5	≤5
Backlash P1		arcmin	15~100	≤7	≤7	≤7	≤7	≤7	≤7	≤7	≤7
Torsional Rigidity		Nm/arcmin	15~100	6	14	27	60	140	240	510	980
Max. Radial Force	F_{2RB}	N	15~100	1,180	3,200	6,800	9,300	15,600	51,000	107,100	224,910
Max. Axial Force	F_{2aB}	N	15~100	590	1,600	3,400	4,650	7,800	25,500	53,550	112,455
Service Life	L_{H1}	hr	15~100	20,000(Continuous Operation 10,000hrs)							
Efficiency	η	%	15~100	≥94							
Operating Temperature		°C	15~100	-25°C~ +90°C							
Lubrication			15~100	VIGO GREASE RE #0							
Protection Class			15~100	IP65							
Mounting Position			15~100	ANY							
Noise Level		dB	15~100	≤58	≤60	≤63	≤65	≤67	≤70	≤72	≤74
Weight ±3%		Kg	15~100	1.68	4.4	9.3	15.5	34.8	56.5	144	221

* 연속운전 사용시 본사와 상담후 선정바랍니다.

KSE

ATG SERVOBOX Planetary Reducers



MODEL : KSE-A

Double Reduction

RATIO : 15. 20. 25. 30. 35. 40. 50. 60. 70. 80. 90. 100

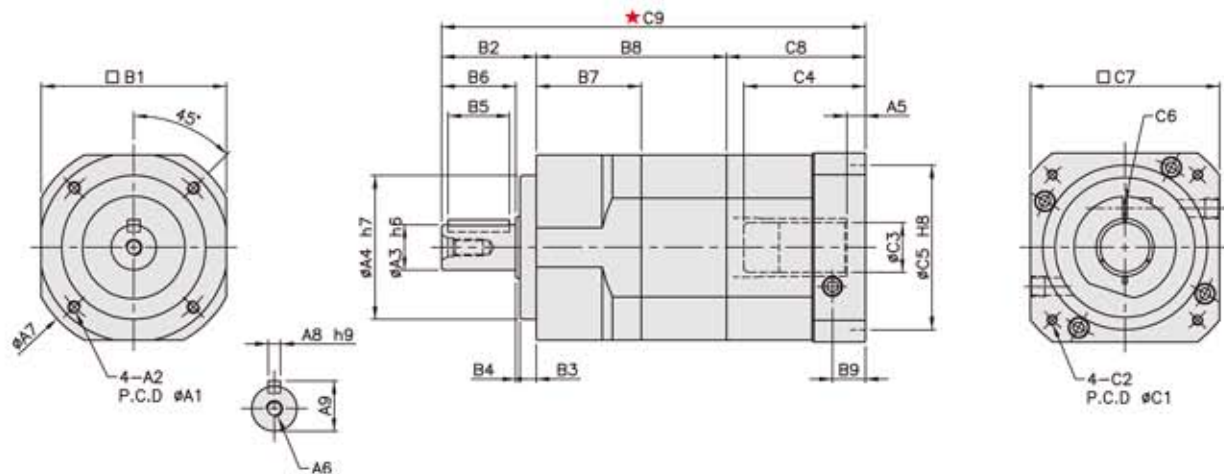

unit:mm

Model code	44A	62A	90A	120A	142A	180A	220A
A A1	44	62	82	110	140	184	218
A2	M4×P0.7	M5×P0.8	M6×P1.0	M8×P1.25	M10×P1.5	M12×P1.75	M16×P2.0
A3	13	16	22	32	40	55	75
A4	35	50	70	90	120	160	180
A5	5	6	9	10	10	11.5	12.5
A6	M4×P0.7	M5×P0.8	M8×P1.25	M10×P1.5	M12×P1.75	M14×P2.0	M16×P2.0
A7	50	70	102	134	166	215	252
A8	5	5	6	10	12	16	20
A9	15	18	24.5	35	43	59	79.5
B B1	44	62	90	120	142	180	220
B2	26	36	46	65	92	106	139
B3	5	7	8	12	15	20	30
B4	1	1	2	3	3	4	5
B5	15	20	30	40	65	70	90
B6	20	28	36	50	74	82	104
B7	31.5	38	51	61	70	85	93
B8	57.5	71.8	94.5	117	136.5	166	186
B9	9	11.5	16	19.5	20	23.5	23.5
C C1	46, 60, 63	70, 75, 90	90, 100, 115, 145	115, 145, 165	145, 165, 215	200, 215, 265	200, 265, 300
C2	M3, M4, M5	M4, M5, M6	M6, M8, M10	M6, M8, M10	M8, M10, M12	M10, M12	M12, M16
C3	8, (11)	14, (19)	19, (24)	24, (32)	35, (38)	38, 42, 48, 55	42, 48, 55
C4	26	33.5, 41.5	46, 59	67	84.5	114.5	117.5
C5	30, 40, 50	50, 60, 70	70, 80, 95, 110	95, 110, 130	110, 130, 180	114.3, 180, 230	114.3, 230, 250
C6	M3×P0.5	M5×P0.8	M6×P1.0	M8×P1.25	M10×P1.5	M10×P1.5	M10×1.5
C7	46, 55	64, 70, 80	92, 110, 130	122, 130, 150	146, 150, 190	182, 200, 250	222, 250, 265
C8	37.5	41, 49	54.5, 67.5	79	98.5	132.5	135.5
C9	121	148.8, 156.8	195, 208	261	327	404.5	460.5



High Precision Planetary Reducer

■ Mass Moments of Inertia (kg · cm²)

Ratio	44A	62A	90A	120A	142A	180A	220A
15	0.03	0.14	0.46	2.63	7.30	22.79	56.98
20	0.03	0.14	0.46	2.63	7.30	22.79	56.98
25	0.03	0.14	0.46	2.63	7.10	22.79	56.98
30	0.03	0.14	0.46	2.43	7.10	22.59	56.48
35	0.03	0.14	0.44	2.43	7.10	22.59	56.48
40	0.03	0.14	0.44	2.43	6.92	22.59	56.48
50	0.03	0.14	0.44	2.39	6.92	22.59	56.48
60	0.03	0.14	0.43	2.39	6.72	21.83	54.58
70	0.03	0.14	0.43	2.39	6.72	21.83	54.58
80	0.03	0.14	0.43	2.39	6.72	21.83	54.58
90	0.03	0.14	0.40	2.39	6.72	21.60	54.00
100	0.03	0.14	0.40	2.39	6.72	21.60	54.00

Model No.		Unit	Ratio	44A	62A	90A	120A	142A	180A	220A
Rated Output Torque (Nominal Output Torque)	T_{2N}	Nm	15	19	59	165	335	625	1,206	2,030
			20	16	51	146	300	555	1,069	1,804
			25	16	48	160	333	618	1,189	2,010
			30	15	45	151	311	583	1,118	1,911
			35	15	45	149	309	573	1,108	1,870
			40	14	43	143	298	553	1,070	1,824
			50	16	48	160	333	618	1,189	2,010
			60	15	45	151	311	583	1,118	1,911
			70	15	45	149	309	573	1,108	1,870
			80	14	43	143	298	553	1,070	1,824
			90	13	44	145	278	516	993	1,694
100	14	43	141	294	549	1,059	1,779			
Max. Acceleration Torque	T_{2B}	Nm	15~100	1.8 Times of Rated Output Torque						
Max. Output Torque Emergency Stop Torque	T_{2NOT}	Nm	15~100	3 Times of Rated Output Torque						
Rated Input Speed	n_{in}	rpm	15~100	5,000	5,000	4,000	4,000	3,000	3,000	2,000
Max. Input Speed	n_{in}	rpm	15~100	10,000	10,000	8,000	8,000	6,000	6,000	4,000
Backlash P _s		arcmin	15~100	-	-	≤3	≤3	≤3	≤3	≤3
Backlash P ₀		arcmin	15~100	≤5	≤5	≤5	≤5	≤5	≤5	≤5
Backlash P ₁		arcmin	15~100	≤7	≤7	≤7	≤7	≤7	≤7	≤7
Torsional Rigidity		Nm/arcmin	15~100	3	6	14	27	60	140	240
Max. Radial Force	F_{2RB}	N	15~100	760	1,180	3,200	6,800	9,300	15,600	51,000
Max. Axial Force	F_{2AB}	N	15~100	380	590	1,600	3,400	4,650	7,800	25,500
Service Life	L_{H1}	hr	15~100	20,000(Continuous Operation 10,000hrs)						
Efficiency	η	%	15~100	≥94						
Operating Temperature		°C	15~100	-25°C~ +90°C						
Lubrication			15~100	VIGO GREASE RE #0						
Protection Class			15~100	IP65						
Mounting Position			15~100	ANY						
Noise Level		dB	15~100	≤56	≤58	≤60	≤63	≤65	≤67	≤70
Weight ±3%		Kg	15~100	0.9	2	6	10.2	22.5	42	59

* 연속운전 사용시 본사와 상담후 선정바랍니다.

KSE

ATG SERVOBOX Planetary Reducers



MODEL : KSE

Triple Reduction

RATIO : 125.150.175.200.250.300.350.

400.450.500.600.700.800.900.1000

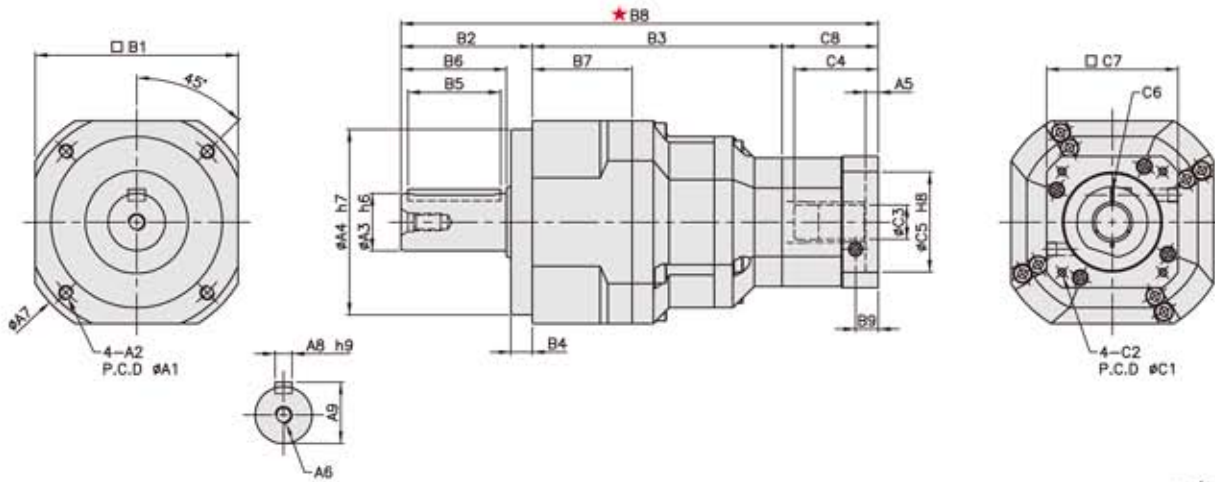

unit:mm

Model code	90	120	142	180	220
A A1	82	110	140	184	218
A2	M6×P1.0	M8×P1.25	M10×P1.5	M12×P1.75	M16×P2.0
A3	22	32	40	55	75
A4	70	90	120	160	180
A5	5	6	9	10	10
A6	M8×P1.25	M10×P1.5	M12×P1.75	M14×P2.0	M16×P2.0
A7	102	134	166	215	252
A8	6	10	12	16	20
A9	24.5	35	43	59	79.5
B B1	90	120	142	180	220
B2	46	65	92	106	139
B3	113.5	143	175	211.5	244
B4	8	12	15	20	30
B5	30	40	65	70	90
B6	36	50	74	82	104
B7	51	61	70	85	93
B8	197	249, 257	321.5, 334.5	396.5	481.5
B9	9	11.5	16	19.5	20
C C1	46, 60, 63	70, 75, 90	90, 100, 115, 145	115, 145, 165	145, 165, 215
C2	M3, M4, M5	M4, M5, M6	M5, M6, M8	M6, M8, M10	M8, M10, M12
C3	8, (11)	14, (19)	19, (24)	24, (32)	35, (38)
C4	26	33.5, 41.5	46, 59	67	84.5
C5	30, 40, 50	50, 60, 70	70, 80, 95, 110	95, 110, 130	110, 130, 180
C6	M3×P0.5	M5×P0.8	M6×P1.0	M8×P1.25	M10×P1.5
C7	46, 55	64, 70, 80	92, 110, 130	122, 130, 150	146, 150, 190
C8	37.5	41, 49	54.5, 67.5	79	98.5



High Precision Planetary Reducer

■ Mass Moments of Inertia (kg · cm²)

Ratio	90	120	142	180	220
125	0.01	0.04	0.71	1.42	3.29
150	0.01	0.04	0.51	0.92	2.15
175	0.01	0.04	0.40	0.83	1.26
200	0.01	0.04	0.21	0.65	0.98
250	0.01	0.04	0.11	0.52	0.82
300	0.01	0.04	0.09	0.21	0.82
350	0.01	0.04	0.09	0.21	0.82
400	0.01	0.04	0.09	0.21	0.82
450	0.01	0.04	0.09	0.21	0.51
500	0.01	0.04	0.08	0.12	0.51
600	0.01	0.04	0.08	0.12	0.25
700	0.01	0.04	0.08	0.12	0.25
800	0.01	0.04	0.08	0.12	0.25
900	0.01	0.04	0.08	0.12	0.25
1000	0.01	0.04	0.08	0.12	0.25

Model No.	Unit	Ratio	90	120	142	180	220	
Rated Output Torque (Nominal Output Torque)	T_{2N}	Nm	125	160	333	618	1,189	2,010
			150	165	335	625	1,206	2,030
			175	149	309	573	1,108	1,870
			200	146	300	555	1,069	1,804
			250	160	333	618	1,189	2,010
			300	151	311	583	1,118	1,911
			350	149	309	573	1,108	1,870
			400	143	298	553	1,070	1,824
			450	145	278	516	993	1,694
			500	160	333	618	1,189	2,010
			600	151	311	583	1,118	1,911
			700	149	309	573	1,108	1,870
Max. Acceleration Torque	T_{2B}	Nm	125-1000	1.8 Times of Rated Output Torque				
Max. Output Torque Emergency Stop Torque	T_{2NOT}	Nm	125-1000	3 Times of Rated Output Torque				
Rated Input Speed	n_{IS}	rpm	125-1000	4,000	4,000	3,000	3,000	2,000
Max. Input Speed	n_{IH}	rpm	125-1000	8,000	8,000	6,000	6,000	4,000
Backlash P5		arcmin	125-1000	-	≤5	≤5	≤5	≤5
Backlash P0		arcmin	125-1000	≤7	≤7	≤7	≤7	≤7
Backlash P1		arcmin	125-1000	≤9	≤9	≤9	≤9	≤9
Torsional Rigidity		Nm/arcmin	125-1000	14	27	60	140	240
Max. Radial Force	F_{2RB}	N	125-1000	3,200	6,800	9,300	15,600	51,000
Max. Axial Force	F_{2aB}	N	125-1000	1,600	3,400	4,650	7,800	25,500
Service Life	L_{H1}	hr	125-1000	20,000(Continuous Operation 10,000hrs)				
Efficiency	η	%	125-1000	≥90				
Operating Temperature		°C	125-1000	-25°C~ +90°C				
Lubrication			125-1000	VIGO GREASE RE #0				
Protection Class			125-1000	IP65				
Mounting Position			125-1000	ANY				
Noise Level		dB	125-1000	≤60	≤63	≤65	≤67	≤70
Weight ±3%		Kg	125-1000	4.9	10	23	47	70

* 연속운전 사용시 본사와 상담후 선정바랍니다.

KSE

ATG SERVOBOX Planetary Reducers



MODEL : KSE-A

Triple Reduction

RATIO : 125.150.175.200.250.300.350.
400.450.500.600.700.800.900.1000

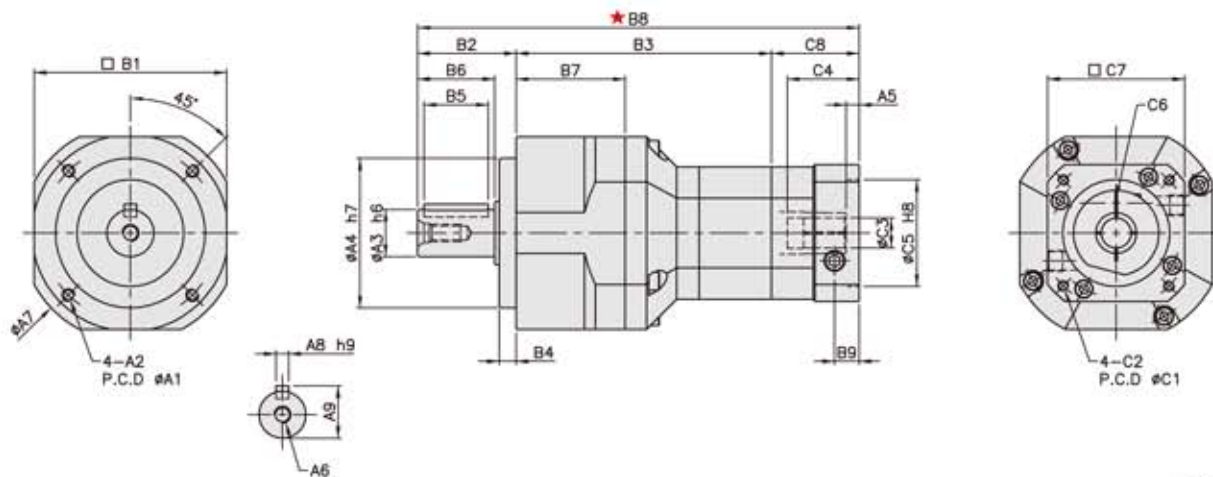

unit:mm

Model code	62A	90A	120A	142A	180A	220A
A1	62	82	110	140	184	218
A2	M5×P0.8	M6×P1.0	M8×P1.25	M10×P1.5	M12×P1.75	M16×P2.0
A3	16	22	32	40	55	75
A4	50	70	90	120	160	180
A5	5	6	9	10	10	11.5
A6	M5×P0.8	M8×P1.25	M10×P1.5	M12×P1.75	M14×P2.0	M16×P2.0
A7	70	102	134	166	215	252
A8	5	6	10	12	16	20
A9	18	24.5	35	43	59	79.5
B1	62	90	120	142	180	220
B2	36	46	65	92	106	139
B3	92	119.5	152	183.5	220.5	256
B4	7	8	12	15	20	30
B5	20	30	40	65	70	90
B6	28	36	50	74	82	104
B7	38	51	61	70	85	93
B8	165.5	206.5, 214.5	271.5, 284.5	354.5	425	527.5
B9	9	11.5	16	19.5	20	23.5
C1	46, 60, 63	70, 75, 90	90, 100, 115, 145	115, 145, 165	145, 165, 215	200, 215, 265
C2	M3, M4, M5	M4, M5, M6	M5, M6, M8	M6, M8, M10	M8, M10, M12	M10, M12
C3	8, (11)	14, (19)	19, (24)	24, (32)	35, (38)	38, 42, 48, 55
C4	26	33.5, 41.5	46, 59	67	84.5	114.5
C5	30, 40, 50	50, 60, 70	70, 80, 95, 110	95, 110, 130	110, 130, 180	114.3, 180, 230
C6	M3×P0.5	M5×P0.8	M6×P1.0	M8×P1.25	M10×P1.5	M10×P1.5
C7	46, 55	64, 70, 80	92, 110, 130	122, 130, 150	146, 150, 190	182, 200, 250
C8	37.5	41, 49	54.5, 67.5	79	98.5	132.5



High Precision Planetary Reducer

■ Mass Moments of Inertia (kg · cm²)

Ratio	62A	90A	120A	142A	180A	220A
125	0.01	0.01	0.04	0.71	1.42	3.29
150	0.01	0.01	0.04	0.51	0.92	2.15
175	0.01	0.01	0.04	0.40	0.83	1.26
200	0.01	0.01	0.04	0.21	0.65	0.98
250	0.01	0.01	0.04	0.11	0.52	0.82
300	0.01	0.01	0.04	0.09	0.21	0.82
350	0.01	0.01	0.04	0.09	0.21	0.82
400	0.01	0.01	0.04	0.09	0.21	0.82
450	0.01	0.01	0.04	0.09	0.21	0.51
500	0.01	0.01	0.04	0.08	0.12	0.51
600	0.01	0.01	0.04	0.08	0.12	0.25
700	0.01	0.01	0.04	0.08	0.12	0.25
800	0.01	0.01	0.04	0.08	0.12	0.25
900	0.01	0.01	0.04	0.08	0.12	0.25
1000	0.01	0.01	0.04	0.08	0.12	0.25

Model No	Unit	Ratio	62A	90A	120A	142A	180A	220A	
Rated Output Torque (Nominal Output Torque)	T_{2N}	Nm	125	48	160	333	618	1,189	2,010
			150	59	165	335	625	1,206	2,030
			175	45	149	309	573	1,108	1,870
			200	51	146	300	555	1,069	1,804
			250	48	160	333	618	1,189	2,010
			300	45	151	311	583	1,118	1,911
			350	45	149	309	573	1,108	1,870
			400	43	143	298	553	1,070	1,824
			450	44	145	278	516	993	1,694
			500	48	160	333	618	1,189	2,010
			600	45	151	311	583	1,118	1,911
			700	45	149	309	573	1,108	1,870
800	43	143	298	553	1,070	1,824			
900	44	145	278	516	993	1,694			
1,000	43	141	294	549	1,059	1,779			
Max. Acceleration Torque	T_{2B}	Nm	125~1000 1.8 Times of Rated Output Torque						
Max. Output Torque Emergency Stop Torque	T_{2NOT}	Nm	125~1000 3 Times of Rated Output Torque						
Rated Input Speed	n_{IN}	rpm	125~1000	5,000	4,000	4,000	3,000	3,000	2,000
Max. Input Speed	n_{IH}	rpm	125~1000	10,000	8,000	8,000	6,000	6,000	4,000
Backlash P _s		arcmin	125~1000	-	-	≤5	≤5	≤5	≤5
Backlash P _D		arcmin	125~1000	≤7	≤7	≤7	≤7	≤7	≤7
Backlash P _I		arcmin	125~1000	≤9	≤9	≤9	≤9	≤9	≤9
Torsional Rigidity		Nm/arcmin	125~1000	6	14	27	60	140	240
Max. Radial Force	F_{2RB}	N	125~1000	1,180	3,200	6,800	9,300	15,600	51,000
Max. Axial Force	F_{2aB}	N	125~1000	590	1,600	3,400	4,650	7,800	25,500
Service Life	L_H	hr	125~1000 20,000(Continuous Operation 10,000hrs)						
Efficiency	η	%	125~1000 ≥90						
Operating Temperature		°C	125~1000 -25°C~ +90°C						
Lubrication			125~1000 VIGO GREASE RE #0						
Protection Class			125~1000 IP65						
Mounting Position			125~1000 ANY						
Noise Level		dB	125~1000	≤58	≤60	≤63	≤65	≤67	≤70
Weight ±3%		Kg	125~1000	2.5	6.5	13	26	56.5	86

* 연속운전 사용시 본사와 상담후 선정바랍니다.

Foot

ATG Planetary Reducers

ACCESSORIES

Foot Type Base Kits

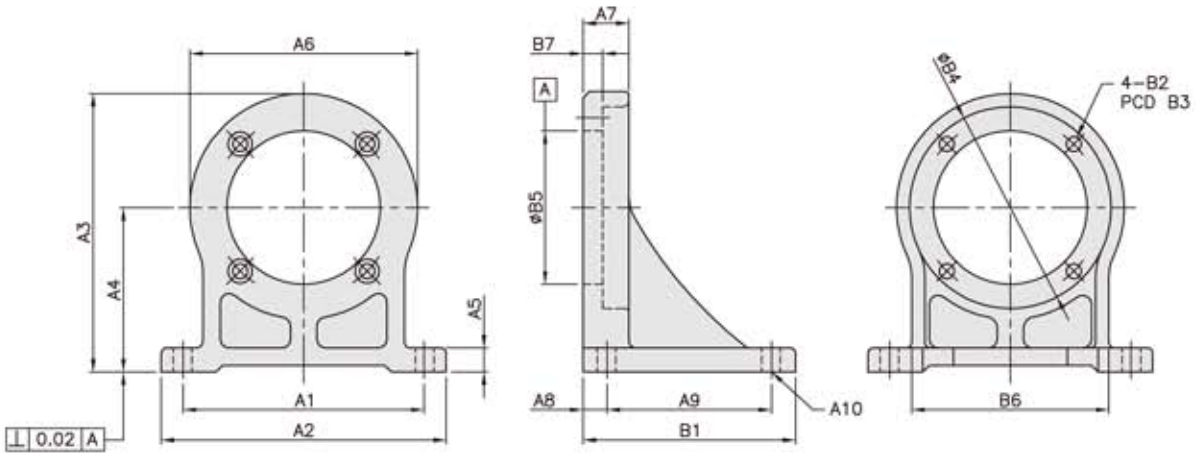

unit:mm

Model Code	44	62	90	120	142	180	220	
A A1	70	90	110	150	190	240	280	
A2	88	108	130	176	220	276	330	
A3	75.5	95.5	127	170	207.5	274	334	
A4	45	55	75	100	120	160	200	
A5	8	9	11	16	19	24	30	
A6	60	81	104	140	175	228	268	
A7	13	16	21	28	35	45	60	
A8	10	10	11	14	16	19	26	
A9	40	50	75	100	120	160	200	
A10	4-Ø7	4-Ø7	4-Ø9	4-Ø11	4-Ø13	4-Ø17	4-Ø21	
B B1	60	70	97	128	152	198	252	
B2	Ø4.5	Ø5.5	Ø6.8	Ø9	Ø11	Ø13	Ø17	
B3	44	62	82	110	140	184	218	
B4	50	70	92	124	155	205	242	
B5	35	50	70	90	120	160	180	
B6	50	70	90	125	156	200	230	
B7	6	8	9	14	16	21	30	
Weight	Kg	0.55	0.71	1.57	3.86	6.41	13.44	27.73



High Precision Planetary Reducer

Connecting Plate

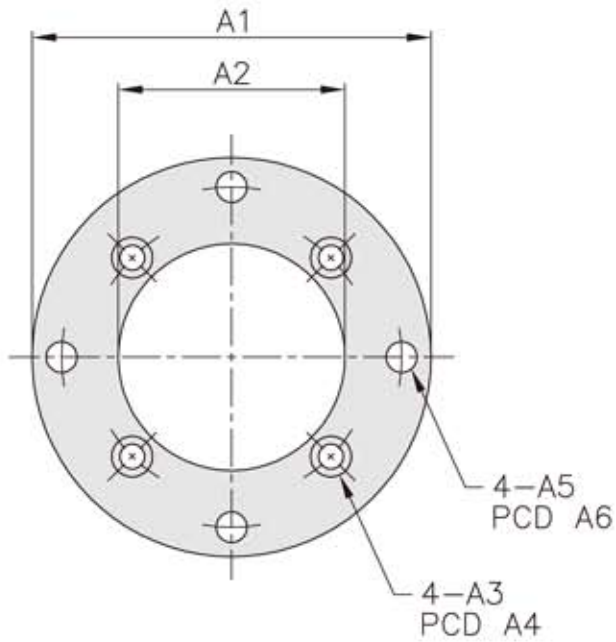

unit: mm

Model Code	unit: mm						
	44	62	90	120	142	180	220
A1	64	88	123	158	188	238	298
A2	35	50	70	90	120	160	180
A3	4.5	5.5	6.8	9	11	13	17
A4	44	62	82	110	140	184	218
A5	5.5	6.8	9	11	13	15	17
A6	54	75	106	140	165	210	260
A7	8	9	11	14	17	22	30